

# ELECTRONIC SHIFT CONTROL SYSTEM

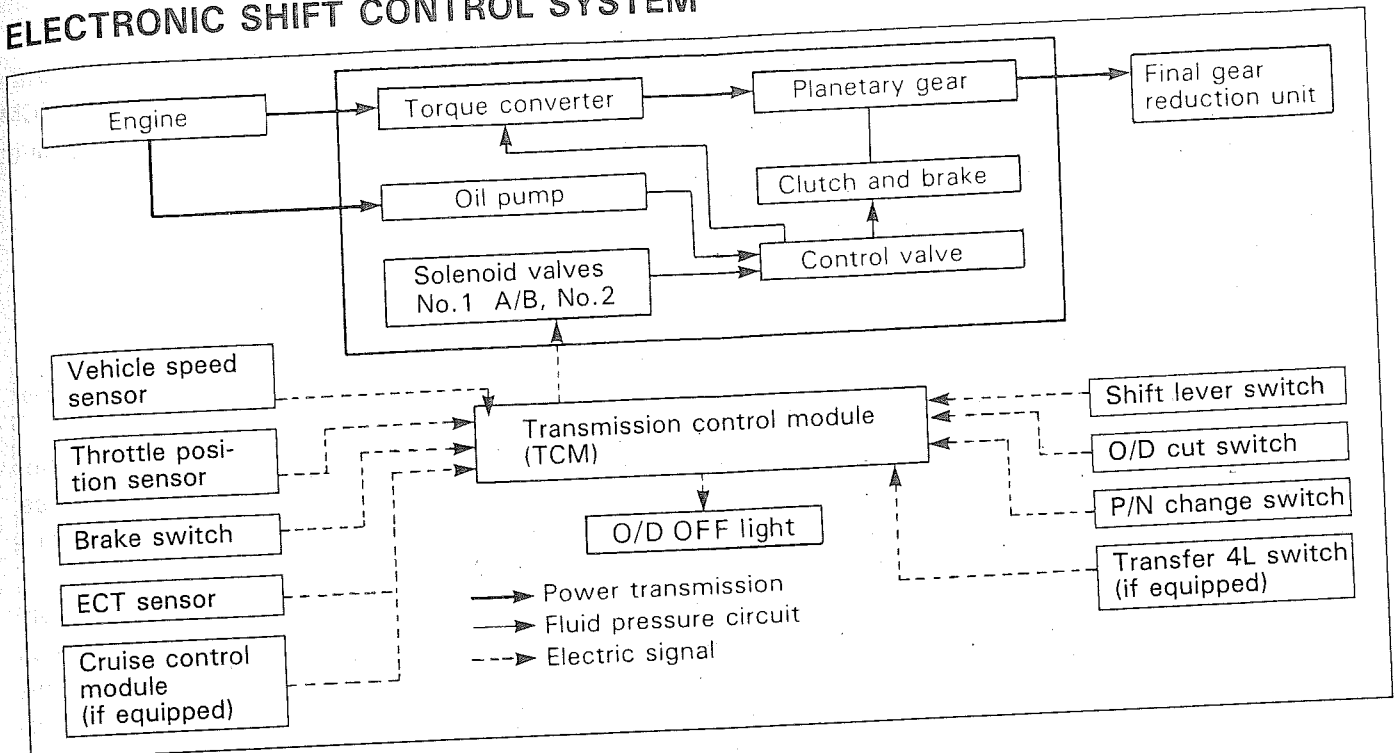

60A90-7B1-45-1S

## TRANSMISSION CONTROL MODULE (TCM)

The TCM is an electronic circuit component that controls gear shift and idle-up according to the signal from each sensor. It is a microcomputer consisting of an IC, transistor, diode, etc. It is installed at the right side of the steering column on LH steering vehicle and at the left side of the steering column on RH steering vehicle.

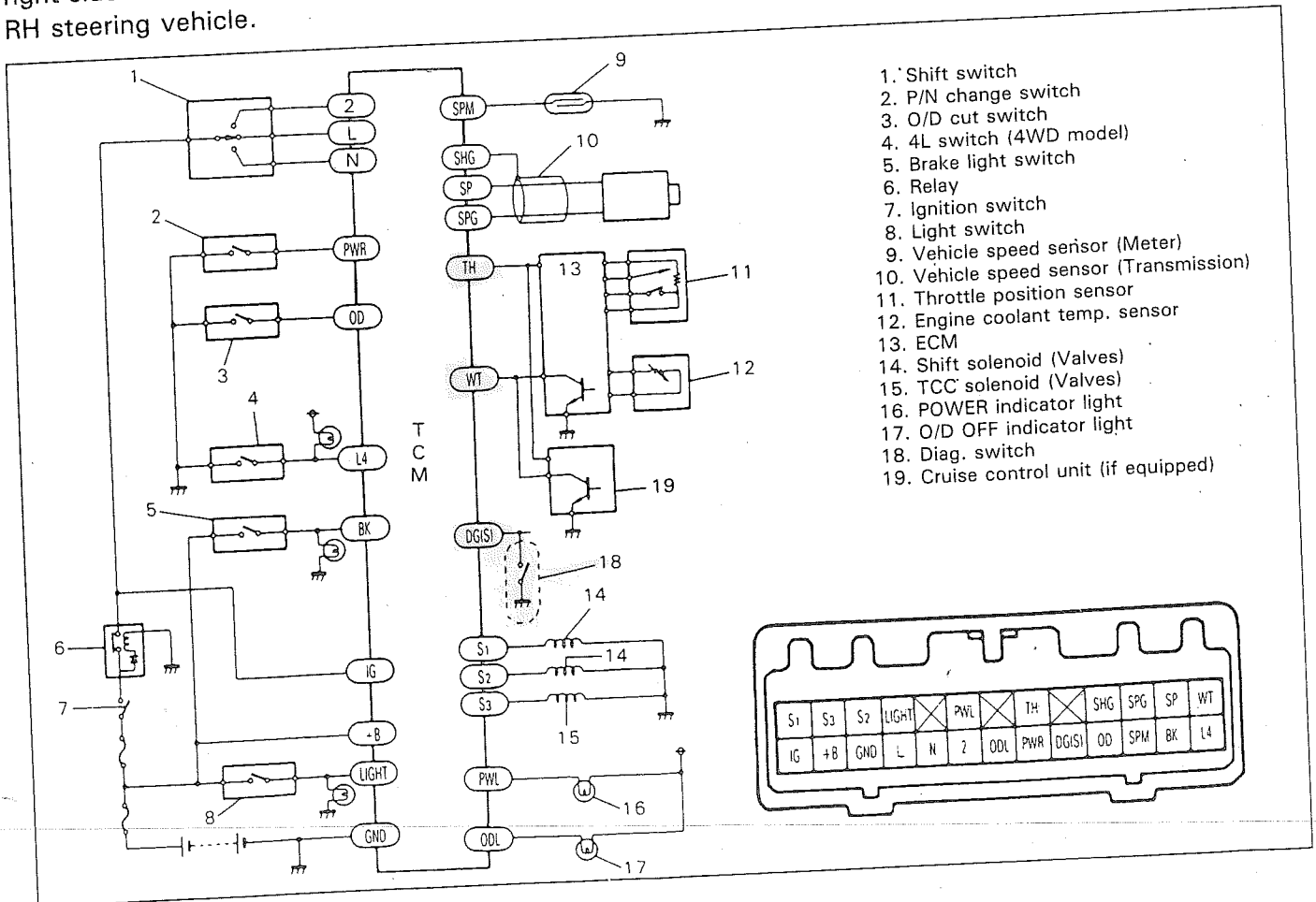

60A90-7B1-45-2S